

**217837 (ECO61B3A31)**

SkyLine Premium Combi Boiler Oven with digital control, 6x1/1GN, electric, programmable, automatic cleaning, boiler in AISI 316L, 3-glass door

Main Features

- Single sensor core temperature probe included.
- Dry, hot convection cycle (25 °C - 300 °C): ideal for low humidity cooking.
- Combination cycle (25 °C - 300 °C): combining convected heat and steam to obtain humidity controlled cooking environment, accelerating the cooking process and reducing weight loss.
- Low temperature Steam cycle (25 °C - 99 °C): ideal for sous-vide, re-thermalization and delicate cooking.
Steam cycle (100 °C): seafood and vegetables.
High temperature steam (101 °C - 130 °C).
- Built-in steam generator for highly precise humidity and temperature control according to the chosen settings.
- Real humidity control based upon Lambda Sensor to automatically recognize quantity and size of food for consistent quality results.
- Automatic fast cool down and pre-heat function.
- Programs mode: a maximum of 100 recipes can be stored in the oven's memory, to recreate the exact same recipe at any time. 4-step cooking programs also available.
- EcoDelta cooking: cooking with food probe maintaining preset temperature difference between the core of the food and the cooking chamber.
- Pre-set program for Regeneration, ideal for banqueting on plate or rethermalizing on tray.
- Fan with 5 speed levels from 300 to 1500 RPM and reverse rotation for optimal evenness. Fan stops in less than 5 seconds when door is opened.
- Back-up mode with self-diagnosis is automatically activated if a failure occurs to avoid downtime.
- 6-point multi sensor core temperature probe for maximum precision and food safety (optional accessory).
- OptiFlow air distribution system to achieve maximum performance in chilling/heating evenness and temperature control thanks to a special design of the chamber.
- GreaseOut: integrated grease drain and collection kit (to use the kit, the oven must be ordered as special code).
- Electrolux Professional recommends the use of treated water to guarantee optimal cooking results and extend the life of the appliance. Check local water condition to select the appropriate water filter. More info available on the website.
- SkyClean: Automatic and built-in self cleaning system with 4 automatic cycles (short, medium, intensive, rinse) and integrated descale of the steam generator.
- Short cleaning cycle: optimized cleaning cycle with a duration of just 33 minutes, improving efficiency and reducing downtime.



Construction

- 304 AISI stainless steel construction throughout
- IPX5 spray water protection certification for easy cleaning.
- Hygienic internal chamber with all rounded corners for easy cleaning.
- Boiler in 316L AISI to protect against corrosion.
- Triple thermo-glazed door with 2 hinged inside panels for easy cleaning and double LED lights line.
- Front access to control board for easy service.

User Interface & Data Management

- USB port to download HACCP data, share cooking programs and configurations. USB port also allows to plug-in sous-vide probe (optional accessory).
- Digital interface with LED backlight buttons with guided selection.
- Connectivity for remote real time access, easy HACCP management, equipment uptime increase, consumption tracking and energy management (requires optional accessory).





A focus on sustainability

Sustainability

- Reduced power function for customized slow cooking cycles.
- Wing-shaped handle with ergonomic design and hands-free opening with the elbow, making managing trays simpler. Protected by registered design (EM003143551 and related family).
- Human centered design with 4-star certification for ergonomics and usability.
- Save energy, water, detergent and rinse aid with SkyClean green functions.
- C22 and C25 detergents are formulated without phosphates and phosphorus (C25 is also maleic acid-free), making them safe for both the environment and human health.
- The outer cardboard packaging is made from 70% recycled materials and FSC*-certified paper, printed with eco-friendly, water-based ink to support sustainability and environmental responsibility. (**Forest Stewardship Council is the world's leading organization for sustainable forest management*).
- Triple-glass door minimize your energy loss.* *Approx. -10% of idle energy consumption in convection based on test in compliance with ASTM Standard F2861-20

Certifications & Recognitions



Product assessed by the manufacturer and deemed to meet EU safety, health, and environmental protection requirements.



International system for mutual acceptance of test reports and certificates concerning the safety of electrical and electronic components, equipment, and products.



Certification for **energy efficiency**, ensuring products meet strict standards for reducing energy consumption, saving money, and helping protect the environment.



Product acceptable for use in a commercial food establishment and meets applicable construction, performance, and material requirements.



Awarded for its ease of use and smooth ergonomic design, it confirms its human-centered approach.



UL Verification is an independent, science-based process that validates marketing claims, helping distinguish verified facts from fiction.



Find out more:
[ISO Certificates](#)
[Electrolux Professional Recognitions](#)

The company reserves the right to make modifications to the products without prior notice. All information correct at time of printing.

2026/05/18

Technical specifications

Electric

Supply voltage:	380-415 V/3N ph/50-60 Hz
Electrical power max.:	11.8 kW
Electrical power, default:	11.1 kW

Water:

Max inlet water supply temperature:	30 °C
Chlorides:	<85 ppm
Conductivity:	>50 µS/cm
Water inlet connections "CW11-CW12":	3/4"
Pressure, bar min/max:	1-6 bar

Capacity:

Trays type:	6 - GN 1/1
Max load capacity:	30 kg

Key Information:

External dimensions, Width:	867 mm
External dimensions, Depth:	775 mm
Weight:	114 kg
External dimensions, Height:	808 mm
Shipping weight (gross):	131 kg
Shipping volume:	0.89 m ³
Runners pitch:	67 mm

ISO Certificates

ISO Standards:	ISO 9001; ISO 14001; ISO 45001; ISO 50001
----------------	---

Installation drawings

Front

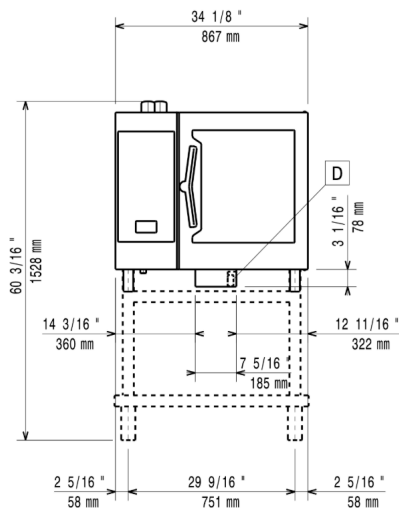

Side

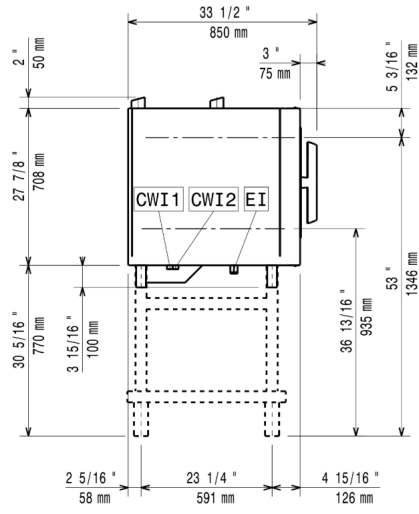

Top

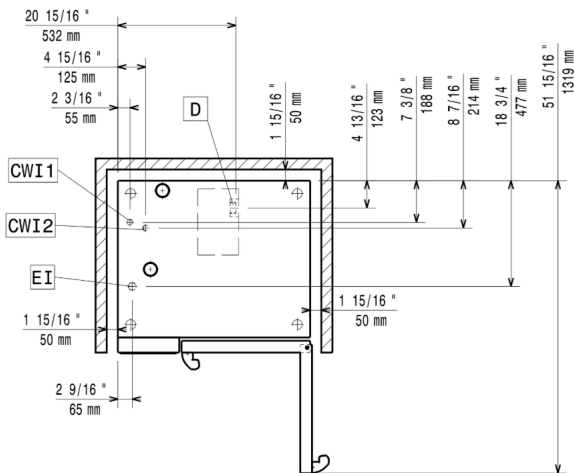

CWI1 = Cold Water inlet 1 (cleaning)
EI = Electrical inlet (power)

D = Drain
DO = Overflow drain pipe

Accessories

Optional Accessories

PNC Code	Description
Bases & base accessories	
922382	Tray support for 6 & 10 GN 1/1 disassembled open base
922612	Open base with tray support for 6 & 10 GN 1/1 oven
922614	Cupboard base with tray support for 6 & 10 GN 1/1 oven
922615	Hot cupboard base with tray support for 6 & 10 GN 1/1 oven holding GN 1/1 or 400x600mm trays
922653	Open base for 6 & 10 GN 1/1 oven, disassembled - NO accessory can be fitted with the exception of 922382
922690	Tray support for 6 & 10 GN 1/1 oven base
922702	Bakery/pastry runners 400x600mm for 6 & 10 GN 1/1 oven base
Cleaning solutions	
922386	Wall mounted detergent tank holder
922618	External connection kit for liquid detergent and rinse aid
922699	Detergent tank holder for open base
Containers, trays and grids	
922017	Pair of AISI 304 stainless steel grids, GN 1/1
922036	Pair of grids for whole chicken (8 per grid - 1,2kg each), GN 1/1
922062	AISI 304 stainless steel grid, GN 1/1
922086	Grid for whole chicken (4 per grid - 1,2kg each), GN 1/2
922189	Baking tray for 5 baguettes in perforated aluminum with silicon coating, 400x600x38mm
922190	Baking tray with 4 edges in perforated aluminum, 400x600x20mm
922191	Baking tray with 4 edges in aluminum, 400x600x20mm
922239	Pair of frying baskets
922264	AISI 304 stainless steel bakery/pastry grid 400x600mm
922266	Grid for whole chicken (8 per grid - 1,2kg each), GN 1/1
922324	Kit universal skewer rack and 4 long skewers for Lenghtwise ovens
922348	Multipurpose hook
922362	Grid for whole duck (8 per grid - 1,8kg each), GN 1/1
922651	Dehydration tray, GN 1/1, H=20mm
922652	Flat dehydration tray, GN 1/1
922713	Mesh grilling grid, GN 1/1
922746	Tray for traditional static cooking, H=100mm
922747	Double-face griddle, one side ribbed and one side smooth, 400x600mm
925000	Non-stick universal pan, GN 1/1, H=20mm
925001	Non-stick universal pan, GN 1/ 1, H=40mm
925002	Non-stick universal pan, GN 1/1, H=60mm
925003	Double-face griddle, one side ribbed and one side smooth, GN 1/1
925004	Aluminum grill, GN 1/1

Accessories

PNC Code	Description
Containers, trays and grids	
925005	Frying pan for 8 eggs, pancakes, hamburgers, GN 1/1
925006	Flat baking tray with 2 edges, GN 1/1
925007	Baking tray for 4 baguettes, GN 1/1
925008	Potato baker for 28 potatoes, GN 1/1
925009	Non-stick universal pan, GN 1/2, H=20mm
925010	Non-stick universal pan, GN 1/2, H=40mm
925011	Non-stick universal pan, GN 1/2, H=60mm
925012	Kit of 6 non-stick universal pans, GN 1/1, H=20mm
925013	Kit of 6 non-stick universal pans, GN 1/1, H=40mm
925014	Kit of 6 non-stick universal pan GN 1/1, H=60mm
Doors and drawers	
922265	Double-step door opening kit
Drains	
922636	Stainless steel drain kit for 6 & 10 GN oven, dia=50mm
922637	Plastic drain kit for 6 & 10 GN oven, dia=50mm
Feet, wheels and ramps	
922003	Wheel kit for 6 & 10 GN 1/1 and 2/1 GN oven base (not for the disassembled one)
922351	4 flanged feet for 6 & 10 GN , 2", 100-130mm
922394	4 service feet for 6 & 10 GN Oven, 100mm - Marine
922688	4 adjustable feet for 6 & 10 GN ovens, 100-115mm
922693	4 adjustable feet with black cover for 6 & 10 GN ovens, 100-115mm
922745	4 high adjustable feet for 6 & 10 GN ovens, 230-290mm
Food probes	
922390	USB single point probe
922714	Probe holder for liquids
Grease/oil management	
922321	Grease collection tray, GN 1/1, H=100 mm
922329	Grease collection tray, GN 1/1, H=40 mm
922752	Trolley for grease collection kit
Handling - bakery	
922607	Bakery/pastry tray rack with wheels 400x600mm for 6 GN 1/1 oven and blast chiller freezer, 80mm pitch (5 runners)
922655	Bakery/pastry rack kit for 6 GN 1/1 oven with 5 racks 400x600mm and 80mm pitch
Handling - gastronorm	
922600	Tray rack with wheels, 6 GN 1/1, 65mm pitch
922606	Tray rack with wheels, 5 GN 1/1, 80mm pitch
922626	Trolley for slide-in rack for 6 & 10 GN 1/1 oven and blast chiller freezer

Accessories

PNC Code	Description
Handling - multipurpose	
922684	Fixed tray rack for 6 GN 1/1 and 400x600mm grids
Installation solutions	
922660	Heat shield for stacked ovens 6 GN 1/1 on 6 GN 1/1
922661	Heat shield for stacked ovens 6 GN 1/1 on 10 GN 1/1
922662	Heat shield for 6 GN 1/1 oven
922774	Kit for installation of electric power peak management system for 6 & 10 GN Oven
Kit compatibility air-o-system	
922679	Compatibility kit for installation of 6 GN 1/1 electric oven on previous 6 GN 1/1 electric oven (old stacking kit 922319 is also needed)
Other accessories	
922338	Volcano Smoker for lengthwise and crosswise oven
Slide-in supports	
922610	Slide-in rack with handle for 6 & 10 GN 1/1 oven
Spray units	
922171	External side spray unit (needs to be mounted outside and includes support to be mounted on the oven)
Stacking kits	
922436	Riser on feet (h=250mm) for 2x6 GN 1/1 ovens or a 6 GN 1/1 oven on base
922620	Stacking kit for 6+6 GN 1/1 ovens on electric 6+10 GN 1/1 GN ovens
922630	Trolley for mobile rack for 6 GN 1/1 on 6 or 10 GN 1/1 ovens
922632	Riser on feet for 2 6 GN 1/1 ovens or a 6 GN 1/1 oven on base
922635	Riser on wheels for stacked 2x6 GN 1/1 ovens, height 250mm
922657	Stacking kit for 6 GN 1/1 combi or convection oven on 15&25kg blast chiller/freezer crosswise
922704	Wheels for stacked ovens
Ventilation	
922440	Steam optimizer
922718	Odour reduction hood with fan for 6 & 10 GN 1/1 electric ovens
922722	Odour reduction hood with fan for 6+6 or 6+10 GN 1/1 electric ovens
922723	Condensation hood with fan for 6 & 10 GN 1/1 electric oven
922727	Condensation hood with fan for stacking 6+6 or 6+10 GN 1/1 electric ovens
922728	Exhaust hood with fan for 6 & 10 GN 1/1 ovens
922732	Exhaust hood with fan for stacking 6+6 or 6+10 GN 1/1 ovens
922733	Exhaust hood without fan for 6&10 1/1GN ovens
922737	Exhaust hood without fan for stacking 6+6 or 6+10 GN 1/1 ovens
922751	Hood Hopper to directly connect the Hood to the centralized ventilation system, for Standard Hoods (with fan motor) and Hoods without fan motor
922776	Extension for condensation tube, 37cm

Accessories

PNC Code	Description
Wall mounting kits	
922643	Wall support for 6 GN 1/1 oven
922687	Kit to fix oven to the wall
Water treatment	
864388	External reverse osmosis filter for single tank Dishwashers with atmosphere boiler and Ovens
920004	Water filter with cartridge and flow meter for low steam usage (less than 2 hours of full steam per day)
920005	Water filter with cartridge and flow meter for medium steam usage
Other accessories	
922326	Universal skewer rack
922327	4 long skewers
922421	IoT module for OnE Connected (Combi Ovens, Blast chiller/freezers, Rack Type DW) and SkyDuo (one IoT board per appliance - to connect oven to blast chiller for Cook&Chill process).
922435	Connectivity router (WiFi and LAN)
922448	Baking tray with 4 edges in perforated aluminum, coated surface, 400x600x20mm
922449	Baking tray with 4 edges in aluminum, coated surface, 400x600x20mm
922451	Grease collection kit for GN 1/1-2/1 open base (2 tanks, open/close device for drain)
922452	Grease collection kit for ovens GN 1/1 & 2/1 (2 plastic tanks, connection valve with pipe for drain)
922453	Grease collection kit for stacked ovens 6 GN on 6 GN 1/1 - 2/1, with riser
922773	Water inlet pressure reducer

Recommended Detergents

PNC Code	Description
0S2394	C25 Rinse & Descale Tabs, phosphate-free, phosphorous-free, maleic acid-free, 50 tabs bucket
0S2395	C22 Cleaning Tabs, phosphate-free, phosphorous-free, 100 bags bucket